

# Balcony Skylight Shade Installation Instructions

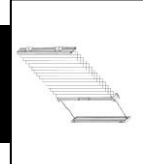

## EXPLODED VIEW

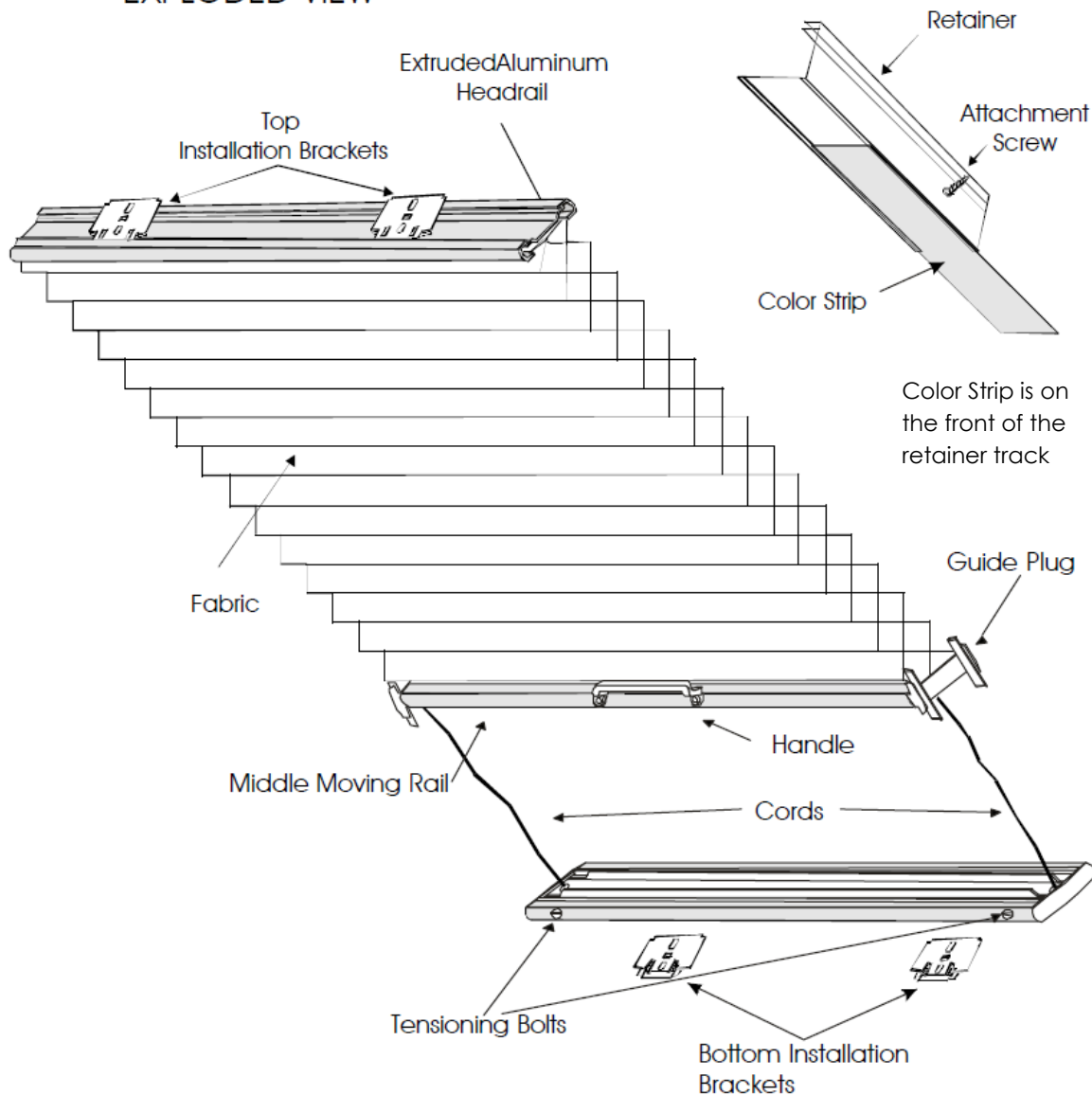

Tools you will need:	Parts included with order:
Scissors Cordless Drill/Screwdriver Flathead Manual Screwdriver Drill Bit Phillips head bit Hex head bit Measuring tape or ruler Pencil	Installation brackets 4 or 6 (over 40" wide) 2 retainer tracks Hex screws Phillips head screws (1 per bracket) Light Blocking strip Tube of lubricant
<b>For best results, read all of the instructions before beginning installation!</b> <b>IMPORTANT: There cannot be more than 1/4" variation in window opening or shimming may be required</b>	

## Retainer Track Installation

- Install the retainer track assembly with screws provided as shown below.
- Screws should be 3/4" from front edge of the retainer track.
- Screws should be placed four (4) inches in from each end and twelve (12) inches apart for intermediate screws. Insert screws into top and bottom holes first to avoid bowing and shifting.
- Left and right tracks must be installed parallel to each other.
- Back of retainer track must be at least 3/4" from any obstruction.

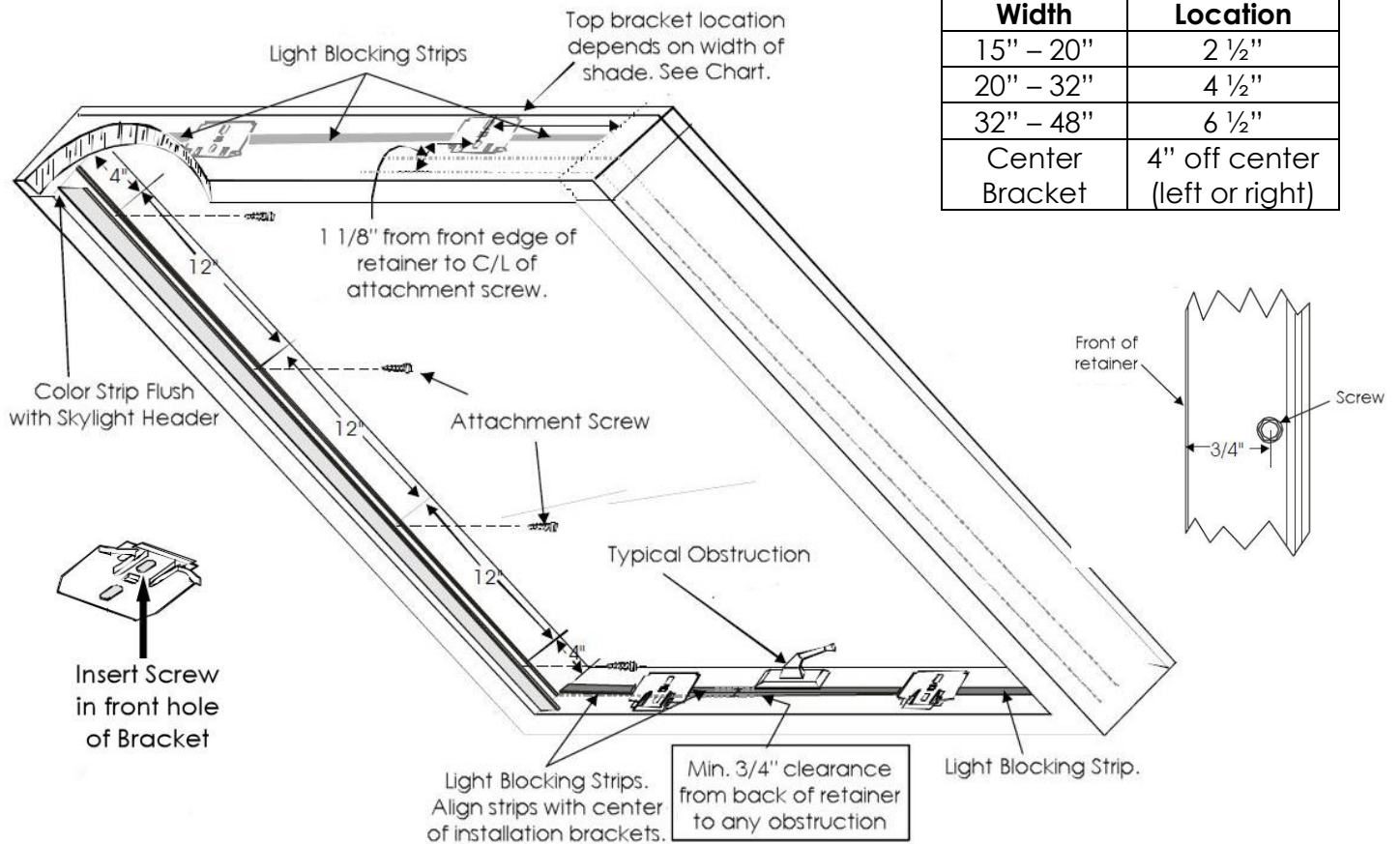

Shade Width	Top Bracket Location
15" – 20"	2 1/2"
20" – 32"	4 1/2"
32" – 48"	6 1/2"
Center Bracket	4" off center (left or right)

## Bracket Installation

Measure and mark the screw location in from the side and 1 1/8" back from the front face of retainer track for accurate screw placement. Screws will be installed in the front hole of the bracket. The flat face of the bracket should be against the mounting surface.

Top Bracket location depends on the width of the shade. Refer to chart for location. If third bracket is required, it should be 4" off center (to either side)

Bottom Brackets should be screwed three inches in from the left and right sides. If third bracket is required, install in the center.

Phillips head screws are supplied for the mounting brackets.

## Light Blocking Strip Application

Note: *Do not* remove paper liner from Light Blocking Strips until they are cut to length.

1. Cut 6 or 8 pieces of Light Blocking Strip to fit between brackets and window casing, on top and bottom sills (see diagram above)
2. Remove paper liner from one piece of Light Blocking Strip. Apply strip to correct area of sill, aligning the strip with the center of the brackets.
3. Press down firmly. *Do not* stretch strip.
4. Repeat steps 2 and 3 for remaining pieces of Light Blocking Strip.

### Lubricant Application

Apply supplied Silicone Grease to ribs of Guide Plugs where shown.

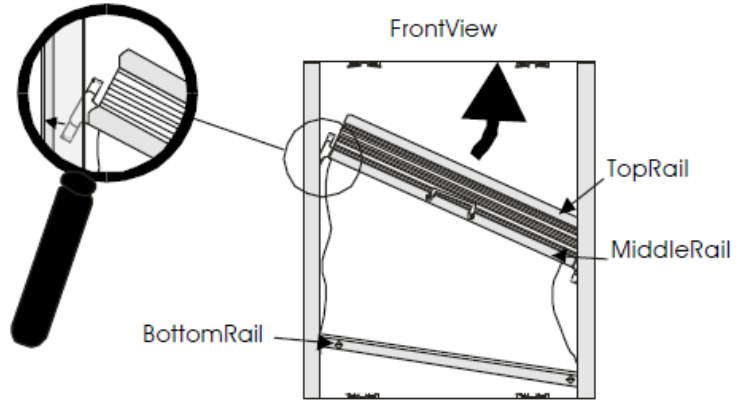
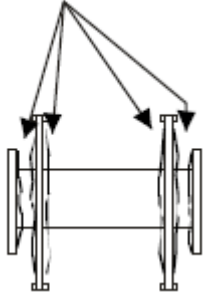

figure 1

Apply a small amount of grease inside the retainer track groove (figure 2) for smooth operation. Save any leftover grease in case future applications are needed.

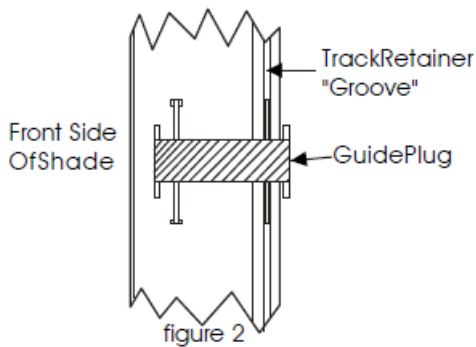

figure 2

### Shade Installation

Tilt compressed top and middle rails to position in retainer track (figure 1). Make sure the cords are hanging freely from the middle rail and are not wrapped around the Guide Plugs. Insert one side of middle rail at a time by positioning "barbed rib" on back side of guide plug into groove of track retainer track (figure 2).

Push Guide Plugs into Track Retainer track all the way, by holding Middle rail securely and pushing rail toward retainer track until you hear

three clicks. Make sure that the Guide Plug is square to the Track Retainer track for smooth operation.

With both sides of the Middle Rail snapped into the track retainer track, slide the middle and top rails up to the top mounting brackets. Lift the top rail up against the bottom of the installation

bracket so that the spring loaded front clip is engaged in the front groove of the rail. Push the rail back and up until the back hooks of the bracket are engaged in the back groove of the rail (figure 4).

With the Top Rail securely fastened to the top installation brackets, you can now secure the Bottom Rail to the bottom installation brackets in the same manner. You will notice that the cords are loose. Check the gap between the fronts of the Head and Bottom Rails and the front side of the retainer track (see figure 5). If the spacing is not uniform, loosen mounting brackets and adjust as necessary.

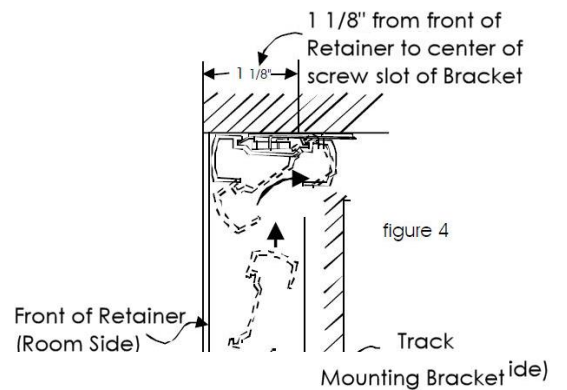

figure 4

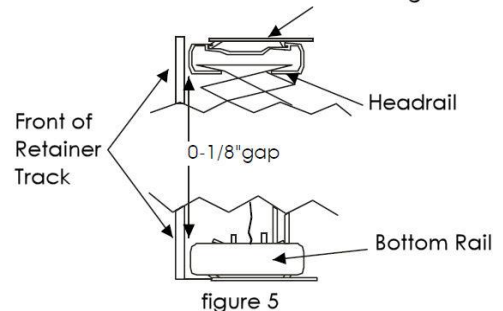

figure 5

## Adjust Cord Tension

Now you will need to adjust the tension in each cord using the Tension Bolts (the screws on the bottom rail). Start by raising the Middle Rail up to the Top Rail, compressing the fabric stack tightly. This will insure the leveling of the Middle Rail. Holding the Middle Rail in that position, start tightening one of the Tensioning Bolts (either side) using a flat head screw driver. When turning the Tensioning Bolt clockwise to tighten, you should see the slack in the cord being removed. The Tensioning Bolt should not be able to turn back by itself. If it does, you need to tighten the nut on the back of the Tensioning Bolt. Turn the bolt until all slack is removed, but cord is not tight. Repeat the process for the opposite side.

The final cord adjustment now needs to be made. The number of turns in tightening the Tensioning Bolts will vary from shade to shade. Start by tightening each side one full turn. Try operating the shade from full open to fully closed. If the shade feels tight or is difficult to move; decrease the amount of tension in each side equally (turn bolt counter clockwise). If shade won't stay all the way opened or closed; increase the amount of tension in each side equally (turn bolt clockwise). If the Middle Rail won't close evenly across the Bottom Rail then you need to adjust one or both of the cords to get equal amounts of tension in each.

When installation is complete, operate the shade up and down several times to evenly distribute the grease. Wipe off any excess grease to prevent it from getting on fabric.

TROUBLE SHOOTING		
Problem	Symptom	Possible Solution
Middle Rail is difficult to move	<ul style="list-style-type: none"> <li>• Tension too tight in cords</li> <li>• Screws in retainer track interfering with Guide Plugs</li> <li>• Guide Plugs not inserted into Track Properly</li> <li>• Insufficient lubrication</li> <li>• Shade too wide</li> </ul>	<ul style="list-style-type: none"> <li>• Loosen Tensioning Bolts</li> <li>• Reposition screw 3/4" back from front of retainer track(see instructions)</li> <li>• Make sure Guide Plugs are pressed into track as far as possible and that the top and bottom of each plug is inserted the same amount</li> <li>• Apply Silicone Grease (see page 3)</li> <li>• Compare width dimensions of shade and area of installation.</li> </ul>
Middle Rail will not stay opened or closed	Tension too loose in cords	Tighten tensioning bolts (A quarter turn at a time)
Middle Rail is not level with Bottom Rail	Unequal tension in Tensioning Bolts	<p><b>Method 1:</b> Move Middle Rail up to Top Rail, compressing fabric. Adjust one or both Tensioning Bolts to obtain equal tension.</p> <p><b>Method 2:</b> Move Middle Rail down to bottom rail. Adjust one or both Tensioning Bolts to make middle rail parallel with bottom rail (Tightening Tension Bolt will lower middle rail on that side, loosening will raise middle rail on that side).</p>

Shades can be operated by an extending pole (optional).

